

BAG IS TO HAVE A TIGHT CURB CONTACT WITH NO GAPS APPROXIMATELY 6-INCHES FROM INLET

LEAVE APPROXIMATELY 4 TO 6 INCHES BETWEEN GRAVEL FILTER BAGS AND INLET

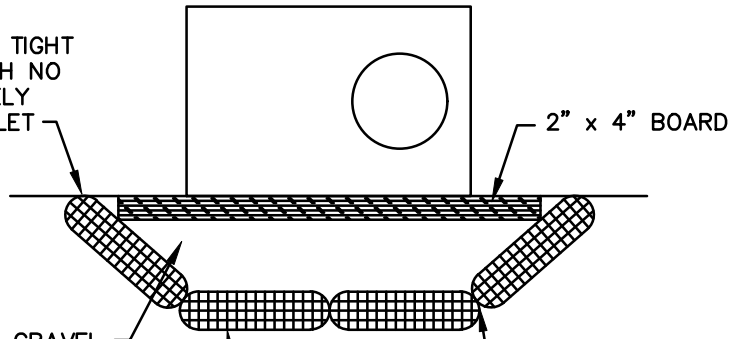

PLACE GRAVEL FILTER BAGS SUCH THAT NO GAPS ARE EVIDENT

3/4-INCH GRAVEL CONTAINED IN PERVIOUS BURLAP BAGS OR SYNTHETIC NET BAGS (1/8-INCH MESH) APPROXIMATELY 24 INCHES LONG, 12 INCHES WIDE, AND 6 INCHES (i.e. CURB HEIGHT) HIGH.

TOP VIEW

HEIGHT OF GRAVEL FILTER BAGS SHOULD NOT BE ABOVE THE INLET TOP

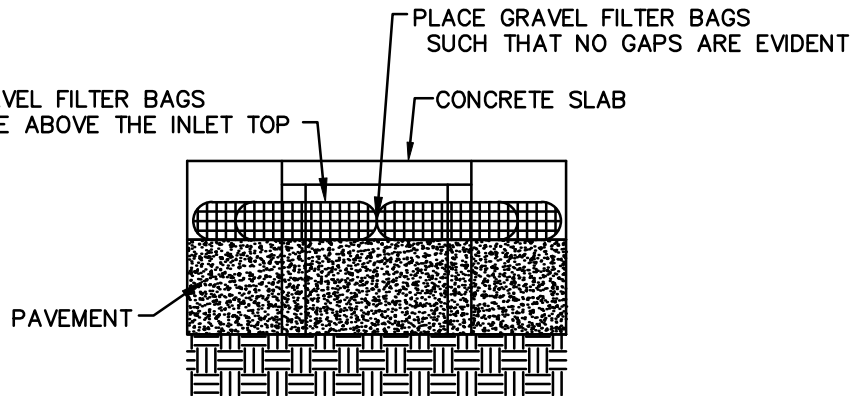

FRONT VIEW

**NOTE:**  
AFTER CONSTRUCTION OF INLETS, FILTER BAGS SHALL BE PLACED AROUND PROPOSED INLETS.

**GRAVEL FILTER BAGS**

(Typical At Every Inlet)  
(Not to Scale)



APPROVED

TRM  
CITY ENGINEER

2-1-07  
DATE

REVISED

5-25-22

EROSION CONTROL  
GRAVEL FILTER BAG

STANDARD  
DETAIL

73-8