

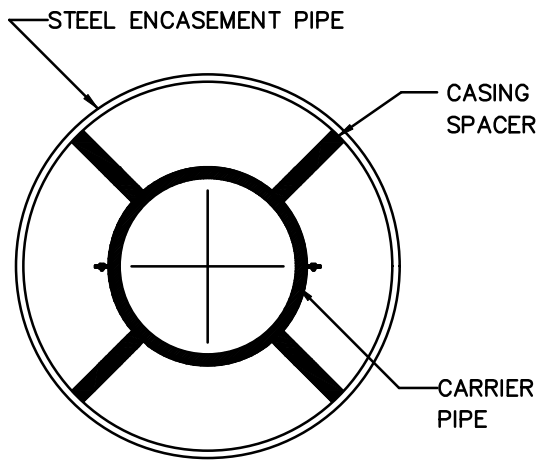

PROFILE



SECTION

NOTES:

1. FILL ALL VOID SPACES OUTSIDE THE CASING PIPE WITH CONTROLLED LOW-STRENGTH MATERIAL (CLSM).
2. DESIGN ENGINEER SHALL OBTAIN SPACING RECOMMENDATION FROM SPACER MANUFACTURER FOR EACH SPECIFIC SITUATION.
3. REFER TO THE TECHNICAL SPECIFICATIONS.

	<i>APPROVED</i> TRM <i>CITY ENGINEER</i>	<i>REVISED</i> 5-25-22	PIPE ENCASEMENT DETAIL	STANDARD DETAIL 50-7
	2-1-07 <i>DATE</i>	 		