

OPTIONAL CURB @ BACK OF SIDEWALK
SEE RAMP CURB DETAIL.

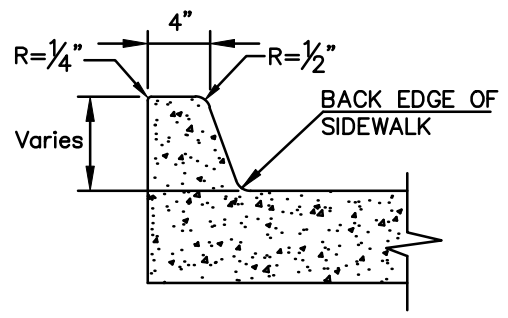

Ramp Curb Detail

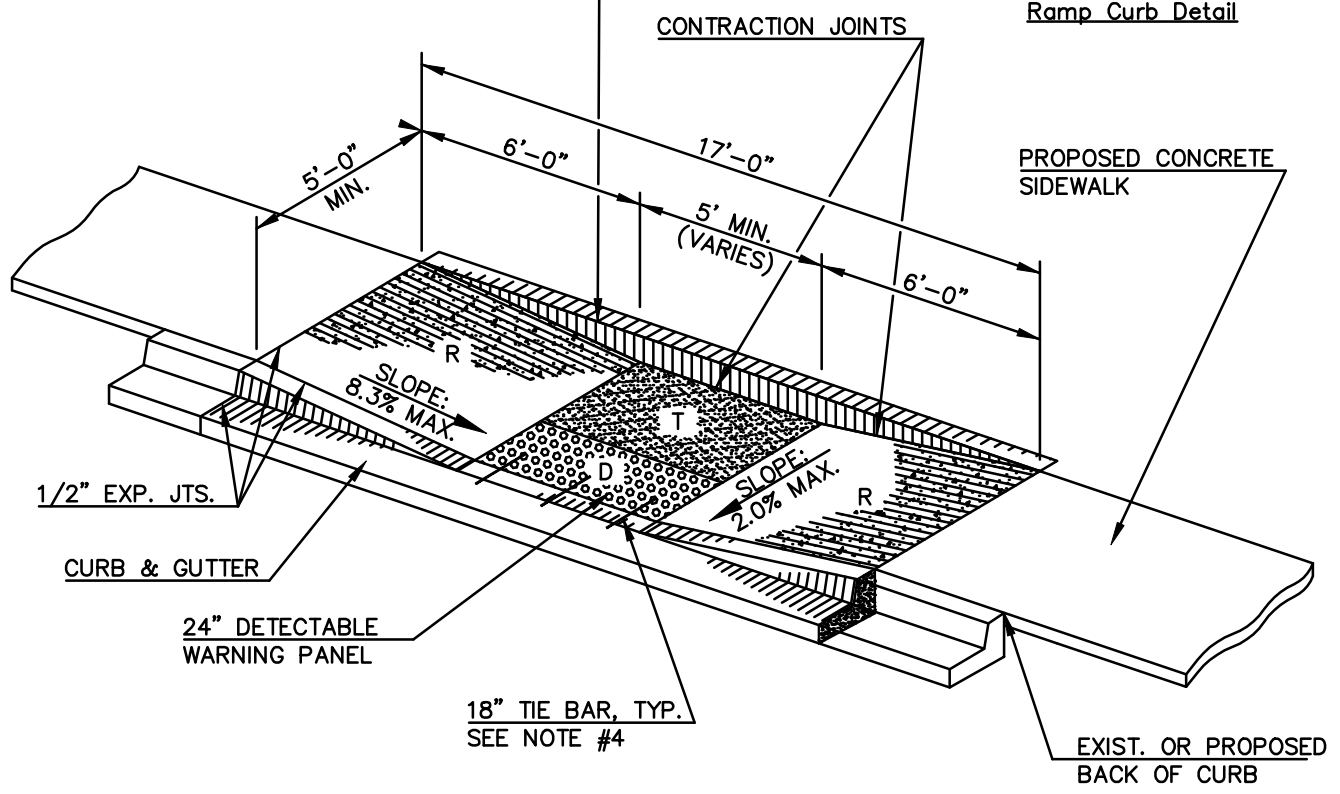

TYPE IV SIDEWALK RAMP

NOTES:

1. ADA MAXIMUM CROSS-SLOPE = 2.0% (1:50)
2. ADA MAXIMUM RAMP SLOPE = 8.3% (1:12)
3. EXPANSION JOINTS SHALL BE PLACED BETWEEN THE RAMP AND SIDEWALK.
4. INSTALL 18" TIE BARS (#4 EPOXY COATED) @ 18" O.C.
5. CONCRETE SHALL BE KCMMB 4K.

LEGEND:

- RAMP
- DETECTABLE WARNING PANEL
- TRANSITION

<p>GARDNER KANSAS <i>Blazing New Trails</i></p>	APPROVED	REVISED	<h2 style="margin: 0;">TYPE IV SIDEWALK RAMP DETAIL</h2>	STANDARD DETAIL	
	<p>TRM CITY ENGINEER</p>	<hr style="border: 0; border-top: 1px solid black;"/> <hr style="border: 0; border-top: 1px solid black;"/> <hr style="border: 0; border-top: 1px solid black;"/>		<hr style="border: 0; border-top: 1px solid black;"/> <hr style="border: 0; border-top: 1px solid black;"/> <hr style="border: 0; border-top: 1px solid black;"/>	21-10C
	<p>5-25-22 DATE</p>	<hr style="border: 0; border-top: 1px solid black;"/> <hr style="border: 0; border-top: 1px solid black;"/> <hr style="border: 0; border-top: 1px solid black;"/>		<hr style="border: 0; border-top: 1px solid black;"/> <hr style="border: 0; border-top: 1px solid black;"/> <hr style="border: 0; border-top: 1px solid black;"/>	