

TYPE A
EXPANSION JOINT

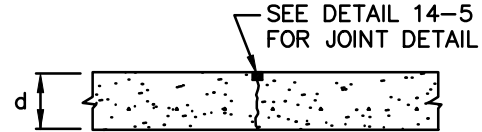

TYPE D
SAWED LONGITUDINAL OR TRANSVERSE

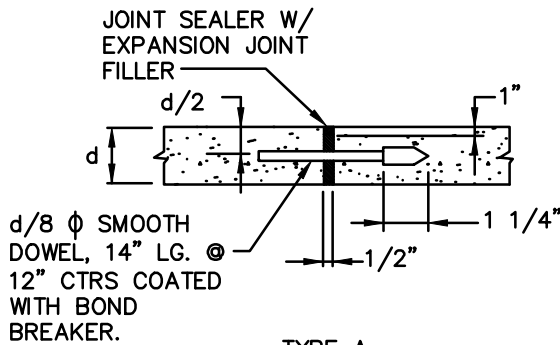

TYPE A
ALTERNATE EXPANSION JOINT

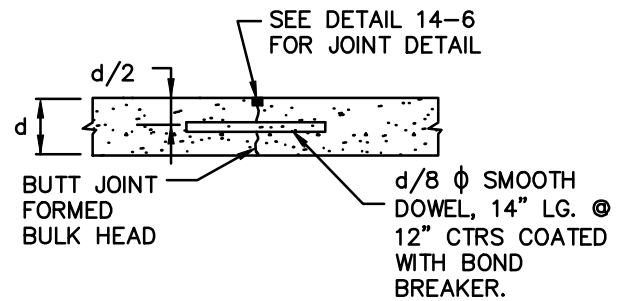

TYPE E
PLANNED TRANSVERSE CONSTRUCTION JOINT
(USED AT NORMAL JOINT SPACING)

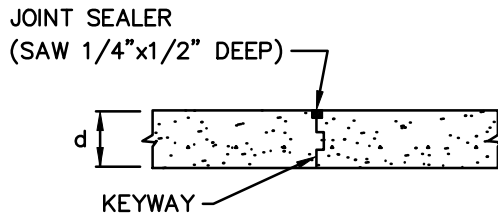

TYPE B
LONGITUDINAL CONSTRUCTION JOINT

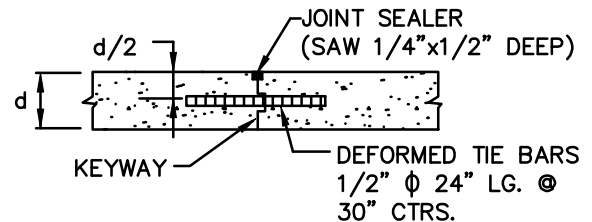

TYPE F
EMERGENCY TIED TRANSVERSE
CONSTRUCTION JOINT

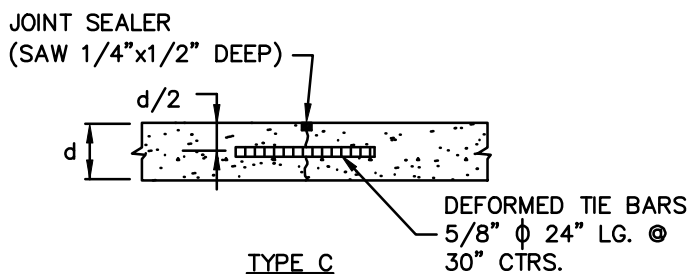

TYPE C
TIED BUTT LONGITUDINAL CONSTRUCTION JOINT

(USED AT MIDDLE THIRD NORMAL JOINT SPACING)

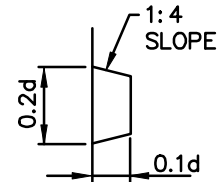

KEYWAYS FOR TYPE B AND F
CONSTRUCTION JOINT

NOTE: ALL DOWELS AND TIE BARS SHALL BE EPOXY COATED.



APPROVED

TRM
CITY ENGINEER

2-1-07
DATE

REVISED

5-25-22

CONCRETE PAVING
JOINT DETAILS

STANDARD
DETAILS

14-4